



figure

216

ends
formflange
angle

STOP VALVE

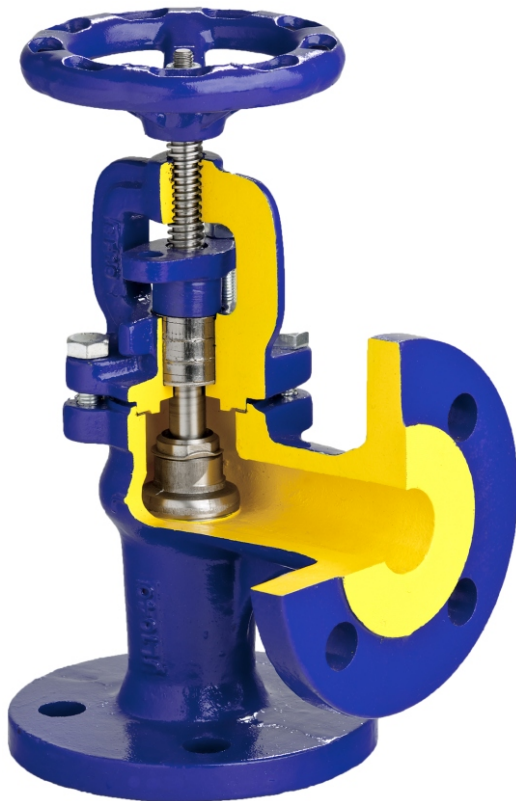

body material	nominal pressure	nominal diameter	max temperature
A grey cast iron	A 6 bar C 16 bar	DN 15-300	300°C
C nodular cast iron	C 16 bar D 25 bar	DN 15-200 DN 15-80	350°C
E bronze	C 16 bar B 10 bar A 6 bar	DN 15-125 DN 150-200 DN 250-300	225°C



correspond to the pressure equipment directive 97/23/EC
marking CE for DN≥32

FEATURES

- high tightness (leakproofness class - A acc. EN -12266 - 1)
- compact settlement
- environment-friendly
- tests acc. EN - 12266 - 1
- flanges drilled according to EN 1092-2
- face-to-face dimension according to EN 558 series 8

APPLICATION

- hot cold and cooling water plants
- steam plants
- industrial technologies
- heat engineering
- power engineering

Data given can be changed without notice.

Edition 10/2012



figure

216

ends
form

flange
angle

MATERIALS

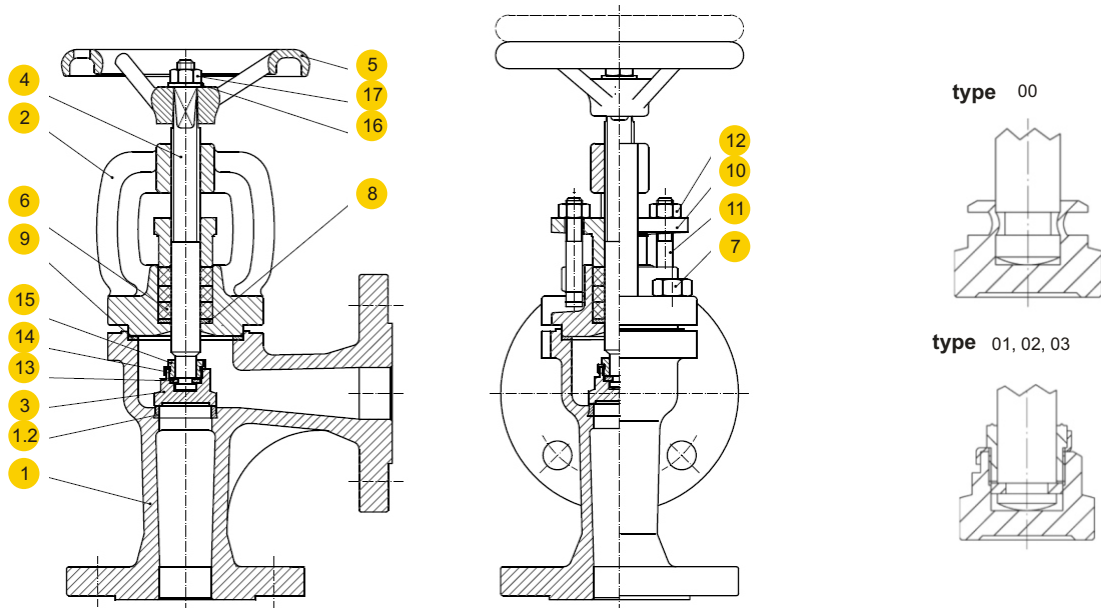

	body material	A				C			E
		type	00	01;04;71;91	02;05;72;92	03;13	01;04;71;91	02;05;72;92	03;13
1	body	EN – GJL-250 5.1301 (ex.JL1040)				EN – GJS-400 – 18-LT 5.3103 (ex.JS1025)			CuSn5Zn5Pb5-C CC491K
1.2	seat ring	X12Cr13 1.4006		CuSn10 – C CC480K		X12Cr13 1.4006	CuSn10 – C CC480K		CuSn5Zn5Pb5-C CC491K
2	bonnet	EN – GJL-250 5.1301 (ex.JL1040)				EN – GJS-400 – 18-LT 5.3103 (ex.JS1025)			CuSn5Zn5Pb5-C CC491K
3	disc	X20Cr13 1.4021		CuSn10 – C CC480K		X20Cr13 1.4021	CuSn10 – C CC480K		CuSn5Zn5Pb5-C CC491K
4	stem	X20Cr13 1.4021	CuZn40Mn1,5	CuSn10 – C CC480K	X20Cr13 1.4021	CuZn40Mn1,5	CuSn10 – C CC480K		CuZn35Ni
5	hand-wheel	EN-GJS500-7 5.3200 (ex.JS1050)							
6	gland packing	graphite							
7	hexagon bolt	8.8			A2-70	8.8		A2-70	
8	washer	X20Cr13 1.4021							
9	gasket	graphite+ NiCr							
10	gland	EN – GJL-250 5.1301 (ex.JL1040)				EN – GJS-400 – 18-LT 5.3103 (ex.JS1025)			CuSn5Zn5Pb5-C CC491K
11	T-bolt	5.8 + zinc galvanized							
12	nut	8 + zinc galvanized							
13	ring	-----	X20Cr13 1.4021	CuSn10 – C CC480K		X20Cr13 1.4021	CuSn10 – C CC480K		CuSn5Zn5Pb5-C CC491K
14	washer	-----	X6CrNiTi18-10 1.4541	CuSn6		X6CrNiTi18-10 1.4541	CuSn6		CuSn6
15	screw	-----	X20Cr13 1.4021	CuSn10 – C CC480K		X20Cr13 1.4021	CuSn10 – C CC480K		CuSn5Zn5Pb5-C CC491K
16	washer	carbon steel + zinc galvanised							
17	nut	8 + zinc galvanised							
max. temperature		300°C	300°C	225°C		350°C	225°C		200°C

Data given can be changed without notice.

Edition 10/2012



figure

216

ends
form

flange
angle

MATERIALS

SCREW-DOWN STOP AND CHECK VALVE

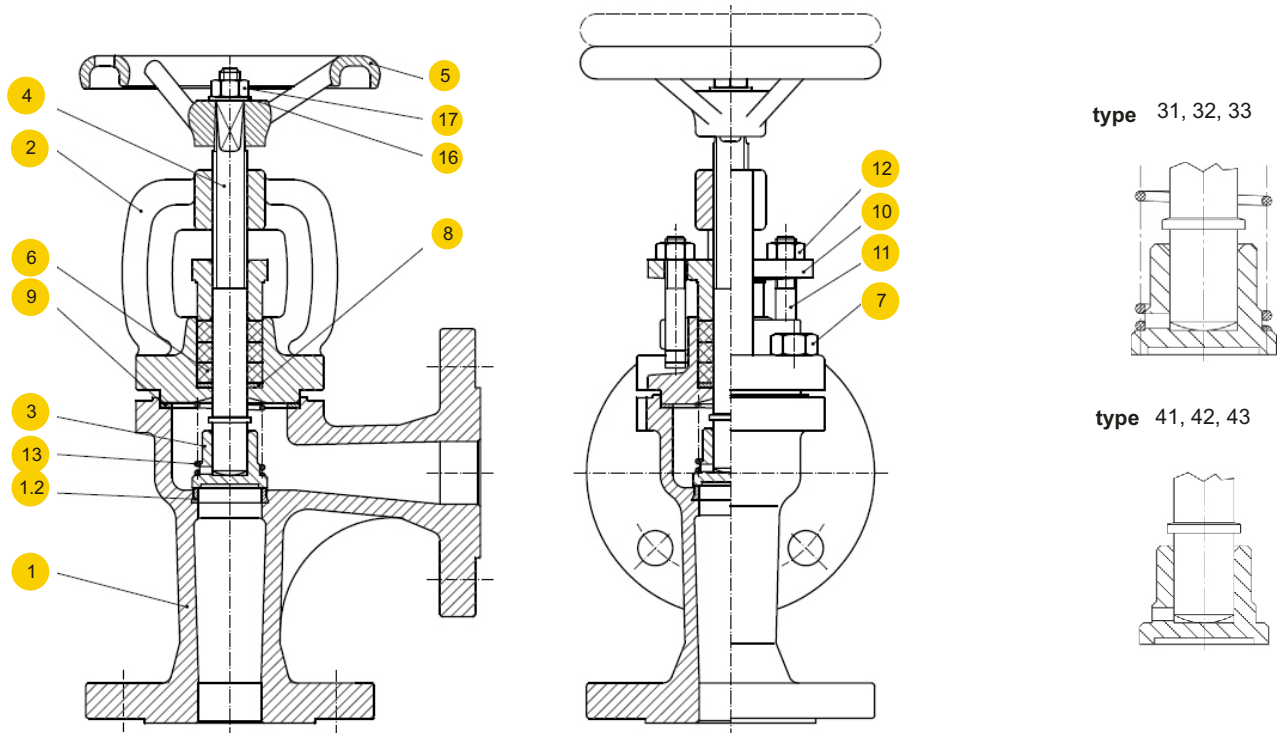

	body material	A			C			E
	type	31;41*	32;42*	33;43*	31;41*	32;42*	33;43*	33;43*;53;63*
1	body	EN – GJL-250 5.1301 (ex.JL1040)			EN – GJS-400 – 18-LT 5.3103 (ex.JS1025)			CuSn5Zn5Pb5-C CC491K
1.2	seat ring	X12Cr13 1.4006	CuSn10 – C CC480K		X12Cr13 1.4006	CuSn10 – C CC480K		CuSn5Zn5Pb5-C CC491K
2	bonnet	EN – GJL-250 5.1301 (ex.JL1040)			EN – GJS-400 – 18-LT 5.3103 (ex.JS1025)			CuSn5Zn5Pb5-C CC491K
3	disc	X20Cr13 1.4021	CuSn10 – C CC480K		X20Cr13 1.4021	CuSn10 – C CC480K		CuSn5Zn5Pb5-C CC491K
4	stem	X20Cr13 1.4021	CuZn40Mn1, 5	CuSn10 – C	X20Cr13 1.4021	CuZn40Mn1, 5	CuSn10 – C	CuZn35Ni
5	hand-wheel	EN-GJS500-7 5.3200 (ex.JS1050)						
6	gland packing	all- graphite						
7	hexagon bolt	8.8			A2-70	8,8		A2-70
8	washer	X20Cr13 1.4021						
9	gasket	graphite+ NiCr						
10	gland	EN – GJL-250 5.1301 (ex.JL1040)			EN – GJS-400 – 18-LT 5.3103 (ex.JS1025)			CuSn5Zn5Pb5-C CC491K
11	T-bolt	5.8 + zinc galvanized						A2-70
12	nut	8 + zinc galvanized						A2-70
13	spring	X17CrNi16- 2	X17CrNi16-2 1.4057		X17CrNi16- 2	X17CrNi16-2 1.4057		CuSn6
14	washer	carbon steel + zinc galvanized						X5CrNi18-10 1.4301
15	nut	8 zinc galvanized						A2-70
max. temperature		350°C	225°C	225°C	350°C	225°C	225°C	200°C

*without spring

Data given can be changed without notice.

Edition 10/2012



figure

216

ends
form

flange
angle

DIMENSIONS

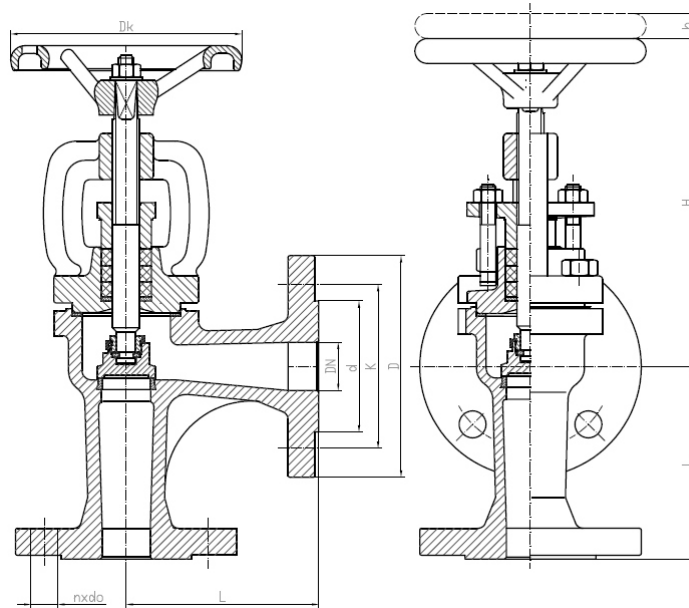

DN	PN 6				PN 16				PN 25				PN 6, 16, 25									
	all types																71 91	00 01 02 03	31 41 32 42 33 43	91	00, 01 02, 03 31, 41 32, 42 33, 43 71	
	D	d	K	n x d	D	d	K	n x d	D	d	K	n x d	Dk	L		Kvs	h			H		
mm															kg	m ³ /h	mm					
15	80	38	55	4x11	95	46	65	4x14	95	46	65	4x14	100	90	3,3	7,2	14	5	5	179	163	
20	90	48	65	4x11	105	56	75	4x14	105	56	75	4x14	100	95	3,9	9,2	14	5,5	5	176	160	
25	100	58	75	4x11	115	65	85	4x14	115	65	85	4x14	120	100	5,0	16,0	25	7	8	198	173	
32	120	69	90	4x14	140	76	100	4x19	140	76	100	4x19	120	105	6,6	22,0	31	14	9	206	173	
40	130	78	100	4x14	150	84	110	4x19	150	84	110	4x19	160	115	8,4	37,0	23	20	12	232	214	
50	140	88	110	4x14	165	99	125	4x19	165	99	125	4x19	160	125	12,0	51,0	29	25	13	235	211	
65	160	108	130	4x14	185	118	145	4x19	185	118	145	8x19	180	145	17,3	98,5	38	35	16	269	236	
80	190	124	150	4x19	200	132	160	8x19	200	132	160	8x19	200	155	22,7	143	45	41	20	290	250	
100	210	144	170	4x19	220	156	180	8x19	-	-	-	-	250	175	35,8	226	40	31	25	336	301	
125	240	174	200	8x19	250	184	210	8x19	-	-	-	-	250	200	52,8	281	48	48	32	374	339	
150	265	199	225	8x19	285	211	240	8x23	-	-	-	-	320	225	74,2	455	54	54	38	433	383	
200	320	254	280	8x19	340	266	295	12x23	-	-	-	-	360	275	126	860	80	77	50	625	455	
250	-	-	-	-	405	319	355	12x28	-	-	-	-	360	325	200	1260	100	120	62	720	531	
300	-	-	-	-	460	370	410	12x28	-	-	-	-	500	375	315	-	100	120	100	779	710	

Data given can be changed without notice.

Edition 10/2012



figure

216

ends
form

flange
angle

PRESSURE-TEMPERATURE RATINGS

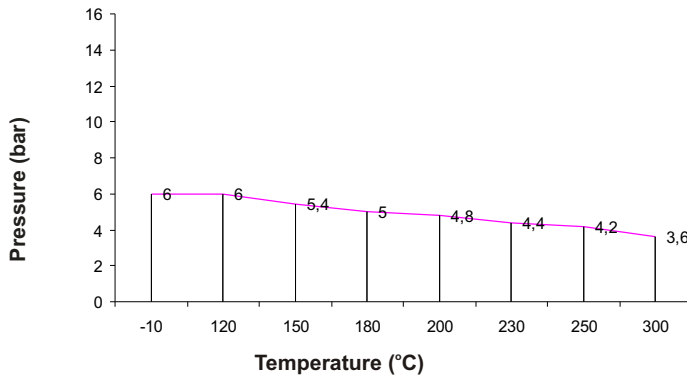

Allowed working conditions range
PN 6 EN-GJL-250

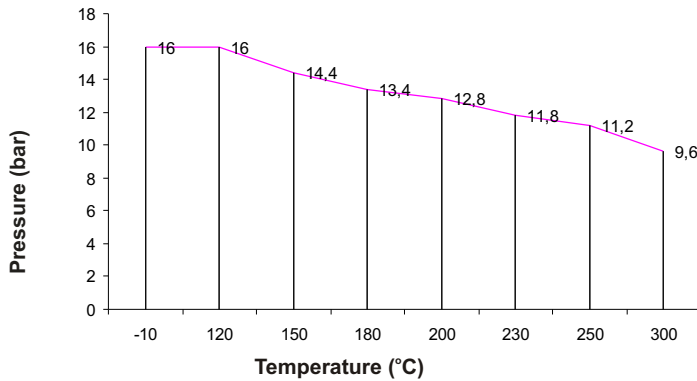

Allowed working conditions range
PN 16 EN-GJL-250

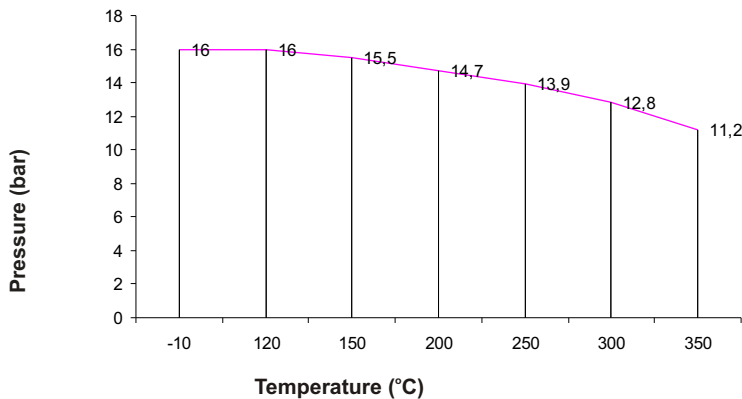

Allowed working conditions range
PN 16 EN-GJS-400-18-LT



figure

216

ends
form

flange
angle

PRESSURE-TEMPERATURE RATINGS

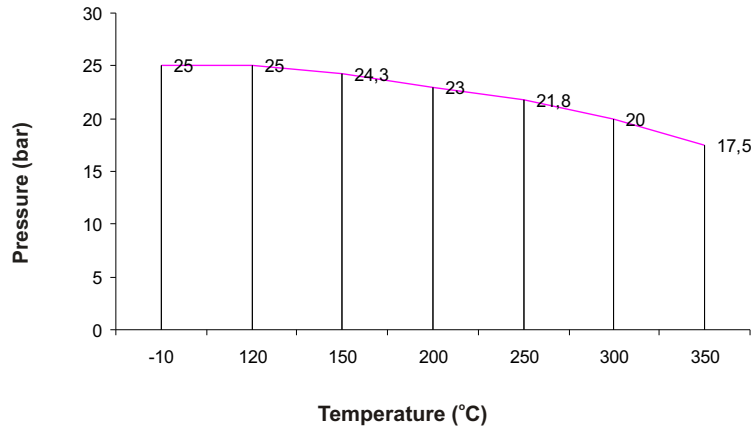

Allowed working conditions range
PN 25 EN-GJS-400-18-LT



figure

216

ends
form

flange
angle

TYPES

figure	body material	nominal diameter DN	nominal pressure PN	type
216	A gray cast iron EN-GJL-250	15-50 mm	A 6bar	00 * stem and disc connection - fixed - rolled * stem, disc and seat ring - stainless steel
		15-150 mm	A 6bar	01 * stem and disc connection - nut * stem, disc and seat ring - stainless steel
		200-300 mm	A 6bar	04 * stem and disc connection - nut * stem, disc and seat ring - stainless steel * balancing disc
		15-150 mm	A 6bar	02 * stem and disc connection nut * stem - brass, disc and seat ring - bronze
		200-300 mm	A 6bar	05 * stem and disc connection - nut * stem - brass, disc and seat ring - bronze * balancing disc
		15-150 mm	A 6bar	03 * stem and disc connection nut * stem, disc and seat ring - bronze
		200-300 mm	A 6bar	13 _y * stem and disc connection - nut * stem, disc and seat ring - bronze * balancing disc
		15-300 mm	A 6bar	31 * loose disc with spring * stem, disc and seat ring - stainless steel
		15-300 mm	A 6bar	41 * loose disc without spring * stem, disc and seat ring - stainless steel
		15-300 mm	A 6bar	32 * loose disc with spring * stem - brass, disc and seat ring - bronze
		15-300 mm	A 6bar	42 * loose disc without spring * stem - brass, disc and seat ring - bronze
		15-300 mm	A 6bar	33 * loose disc with spring * stem, disc and seat ring - bronze
		15-300 mm	A 6bar	43 * loose disc without spring * stem, disc and seat ring - bronze
		15-300 mm	A 6bar	71 * stem and disc connection - nut * stem, throttling disc and seat ring - stainless steel * throttling disc * without position indicator
		15-300 mm	A 6bar	91 * stem and disc connection - nut * stem, throttling disc and seat ring - stainless steel * throttling disc * with position indicator
		15-300 mm	A 6bar	92 * stem and disc connection - nut * stem - brass, throttling disc and seat ring - bronze * throttling disc * with position indicator

Data given can be changed without notice.

Edition 10/2012



figure **216**

ends form flange angle

TYPES

figure	body material	nominal diameter DN	nominal pressure PN	type
216	A gray cast iron EN-GJL-250	15-50 mm	C 16bar	00 * stem and disc connection - fixed - rolled * stem, disc and seat ring - stainless steel
		15-150 mm	C 16bar	01 * stem and disc connection - nut * stem, disc and seat ring - stainless steel
		200-300 mm	C 16bar	04 * stem and disc connection - nut * stem, disc and seat ring - stainless steel * balancing disc
		15-150 mm	C 16bar	02 * stem and disc connection nut * stem - brass, disc and seat ring - bronze
		200-300 mm	C 16bar	05 * stem and disc connection - nut * stem - brass, disc and seat ring - bronze * balancing disc
		15-150 mm	C 16bar	03 * stem and disc connection nut * stem, disc and seat ring - bronze
		200-300 mm	C 16bar	13 * stem and disc connection - nut * stem, disc and seat ring - bronze * balancing disc
		15-300 mm	C 16bar	31 * loose disc with spring * stem, disc and seat ring - stainless steel
		15-300 mm	C 16bar	41 * loose disc without spring * stem, disc and seat ring - stainless steel
		15-300 mm	C 16bar	32 * loose disc with spring * stem - brass, disc and seat ring - bronze
		15-300 mm	C 16bar	42 * loose disc without spring * stem - brass, disc and seat ring - bronze
		15-300 mm	C 16bar	33 * loose disc with spring * stem, disc and seat ring - bronze
		15-300 mm	C 16bar	43 * loose disc without spring * stem, disc and seat ring - bronze
		15-300 mm	C 16bar	71 * stem and disc connection - nut * stem, throttling disc and seat ring - stainless steel * throttling disc * without position indicator
		15-300 mm	C 16bar	91 * stem and disc connection - nut * stem, throttling disc and seat ring - stainless steel * throttling disc * with position indicator
		15-300 mm	C 16bar	72 * stem and disc connection - nut * stem - brass, throttling disc and seat ring - bronze * throttling disc * without position indicator
		15-300 mm	C 16bar	92 * stem and disc connection - nut * stem - brass, throttling disc and seat ring - bronze * throttling disc * with position indicator

Data given can be changed without notice.

Edition 10/2012



figure **216**

ends form flange angle

TYPES

figure	body material	nominal diameter DN	nominal pressure PN	type
216	C nodular cast iron EN-GJS-400-18-LT	15-150 mm	C 16bar	01 • stem and disc connection - nut • stem, disc and seat ring - stainless steel
		200 mm	C 16bar	04 • stem and disc connection - nut • stem, disc and seat ring - stainless steel • balancing disc
		15-150 mm	C 16bar	02 • stem and disc connection nut • stem - brass, disc and seat ring - bronze
		200 mm	C 16bar	05 • stem and disc connection - nut • stem - brass, disc and seat ring - bronze • balancing disc
		15-150 mm	C 16bar	03 • stem and disc connection nut • stem, disc and seat ring - bronze
		200 mm	C 16bar	13 • stem and disc connection - nut • stem, disc and seat ring - bronze • balancing disc
		15-200 mm	C 16bar	31 • loose disc with spring • stem, disc and seat ring - stainless steel
		15-200 mm	C 16bar	41 • loose disc without spring • stem, disc and seat ring - stainless steel
		15-200 mm	C 16bar	32 • loose disc with spring • stem - brass, disc and seat ring - bronze
		15-200 mm	C 16bar	42 • loose disc without spring • stem - brass, disc and seat ring - bronze
		15-200 mm	C 16bar	33 • loose disc with spring • stem, disc and seat ring - bronze
		15-200 mm	C 16bar	43 • loose disc without spring • stem, disc and seat ring - bronze
		15-200 mm	C 16bar	71 • stem and disc connection - nut • stem, throttling disc and seat ring - stainless steel • throttling disc • without position indicator
		15-200 mm	C 16bar	91 • stem and disc connection - nut • stem, throttling disc and seat ring - stainless steel • throttling disc • with position indicator
		15-200 mm	C 16bar	72 • stem and disc connection - nut • stem - brass, throttling disc and seat ring - bronze • throttling disc • without position indicator
		15-200 mm	C 16bar	92 • stem and disc connection - nut • stem - brass, throttling disc and seat ring - bronze • throttling disc • with position indicator

Data given can be changed without notice.

Edition 10/2012



figure

216

ends
form

flange
angle

TYPES

figure	body material	nominal diameter DN	nominal pressure PN	type
216	C nodular cast iron EN-GJS-400-18-LT	15-150 mm	D 25bar	01 • stem and disc connection - nut • stem, disc and seat ring - stainless steel
		15-150 mm	D 25bar	02 • stem and disc connection nut • stem - brass, disc and seat ring - bronze
		200 mm	D 25bar	05 • stem and disc connection - nut • stem - brass, disc and seat ring - bronze • balancing disc
		15-150 mm	D 25bar	03 • stem and disc connection nut • stem, disc and seat ring - bronze
		15-200 mm	D 25bar	31 • loose disc with spring • stem, disc and seat ring - stainless steel
		15-200 mm	D 25bar	41 • loose disc without spring • stem, disc and seat ring - stainless steel
		15-200 mm	D 25bar	32 • loose disc with spring • stem - brass, disc and seat ring - bronze
		15-200 mm	D 25bar	42 • loose disc without spring • stem - brass, disc and seat ring - bronze
		15-200 mm	D 25bar	33 • loose disc with spring • stem, disc and seat ring - bronze
		15-200 mm	D 25bar	43 • loose disc without spring • stem, disc and seat ring - bronze
		15-200 mm	D 25bar	71 • stem and disc connection - nut • stem, throttling disc and seat ring - stainless steel • throttling disc • without position indicator
		15-200 mm	D 25bar	91 • stem and disc connection - nut • stem, throttling disc and seat ring - stainless steel • throttling disc • with position indicator



figure

216

ends
formflange
angle
TYPES

figure	body material	nominal diameter DN	nominal pressure PN	type
216	E bronze CuZn5Zn5Pb5-C	15-125 mm	C 16bar	03 * stem and disc connection - nut * stem, disc and seat ring - bronze
		150-200 mm	B 10bar	33 * loose disc with spring * stem, disc and seat ring - bronze
		250-300 mm	A 6bar	43 * loose disc without spring * stem, disc and seat ring - bronze
				23 * stem and disc connection - nut * with position indicator * stem, disc and seat ring - bronze
				53 * loose disc with spring * with position indicator * stem, disc and seat ring - bronze
				63 * loose disc without spring * with position indicator * stem, disc and seat ring - bronze
		15-150 mm	C 16bar	73 * stem and disc connection - nut * throttling disc - bronze * without position indicator
		15-150 mm	C 16bar	93 * stem and disc connection - nut * throttling disc - bronze * with position indicator



figure	216
ends form	flange angle

ORDERING

To place an order please use our product number (index)



ORDER EXAMPLE

216 A 040 C 00

