



DESCRIPTION:

The PT31AV air vent is designed to remove air and non-condensable gases from steam systems. The removal of these gases is important for achieving better start-up efficiency and heat transfer in normal running.

SIZES: 1/4", 3/8", 1/2", 3/4"

CONNECTIONS: Screwed (NPT)



MATERIAL:

No.	PART	MATERIAL	QTY. (Nos.)
1.	BODY	A 351 CF 8	01
2.	COVER	A 351 CF 8	01
3.	CONTROLLER	Stainless steel	01
4.	STRAINER SCREEN	AISI 304 Perforated Sheet	01
5.	GASKET	Copper	01

DIMENSIONS: (approx.) in inches

SIZE	Ø D	L	Weight (lbs)
1/4", 3/8", 1/2", 3/4"	2.05	2.20	1

LIMITING CONDITIONS:

PMO: Max. operating pressure	315 psig
TMO: Max. operating temperature	480 °F

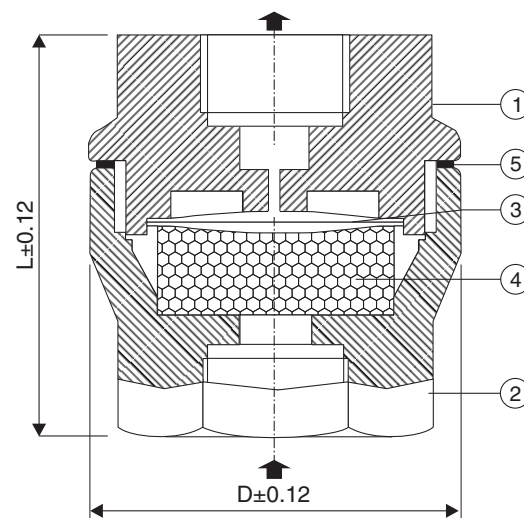

INSTALLATION:

Preferably vertical with inlet from below.

AVAILABLE SPARES:

Controller, Strainer Screen, Gasket.

Local regulations may restrict the use of this product below the conditions quoted. Limiting conditions refer to standard connections only. In the interest of development and improvement of the product, we reserve the right to change the specifications without prior notice.

